

AFBR-8420Z

CFP2, 850 nm, 3.3 V, 100GBASE-SR10 Compliant
Pluggable Ethernet Optical Transceiver



Product Brief - Preliminary



Description

Avago Technologies' AFBR-8420Z CFP2 SR10 is a ten channel pluggable, parallel, fiber optic transceiver for 100Gbps Ethernet Applications. The transceiver supports high speed serial links over multi-mode fiber at signaling rates up to 103.125Gb/s (a serial line rate of 10.3125Gb/s per channel) for link distances up to 100m with OM3 fiber. The product is compliant with the CFP2 industry agreement for mechanical and low speed electrical specifications. High speed electrical and optical specifications are compliant with IEEE 802.3ba Clause 86 for 100GBASE-SR10 media, Clause 86A for CPPI electrical interface, Clause 83A for CAUI electrical interface and Clause 45 for MDIO.

The transceiver electrical interface uses a 104 contact edge type connector, as specified in the CFP2 industry agreement. The optical interface uses a 24-fiber MTP® (MPO) fiber optic connector. This transceiver incorporates Avago Technologies proven integrated circuit and VCSEL technologies to provide reliable, high performance and consistent service.

Digital diagnostic monitoring information (DMI) is present in the AFBR-8420Z per the CFP2 industry agreement, providing real time monitoring information of transmitter, receiver and module operating conditions over the MDIO interface.

Applications

- 100 Gb/s Ethernet Interconnects (802.3ba Clause 86)
- 10×10 Gb/s Ethernet Interconnects (802.3ae Clause 52)
- Datacom/Telecom Switch and Router Connections
- Data Aggregation and Density Applications

Patent - www.avagotech.com/patents

Features

- Compliant to RoHS directives
- Compliant to CFP2 industry agreement
- Utilizes CFP2 "ALT1" electrical pin configuration for 10 wide electrical interfaces
- Compliant to 100GbE specifications 802.3ba (100GBASE-SR10, CAUI and CPPI) up to 100 m OM3 and 150 m OM4 fiber
- Interoperable with 10GbE transceivers that are compliant to 802.3ae 10GBASE-SR specifications with receiver overload up to 2.4 dBm max
- Links up to 100 m using OM3 fiber and 150 m using OM4 fiber
- 850 nm Vertical Cavity Surface Emitting Laser (VCSEL)
- Class 1 eye safe per IEC60825-1 and CDRH
- Wide case temperature range (0 °C to 70 °C)
- Utilizes standard 24 lane optical fiber with MTP® (MPO) optical connector for high density and thin, light-weight cable management
- Diagnostic features per CFP2 using MDIO. Real-time monitoring of:
 - Transmitter average optical power
 - Received average optical power
 - Laser bias current
 - Temperature
 - Supply Voltage
- Mechanical specifications per CFP2 Agreement
- Proven High Reliability 850 nm technology: Avago VCSEL array transmitter and Avago PIN array receiver
- Integrated CDRs on each transmit and receive lane for CAUI compliance can be bypassed for lower power dissipation CPPI interfaces

This preliminary data is provided to assist you in the evaluation of product(s) currently under development. Until Avago Technologies releases this product for general sales, Avago Technologies reserves the right to alter prices, specifications, features, capabilities, functions, release dates, and remove availability of the product(s) at anytime.

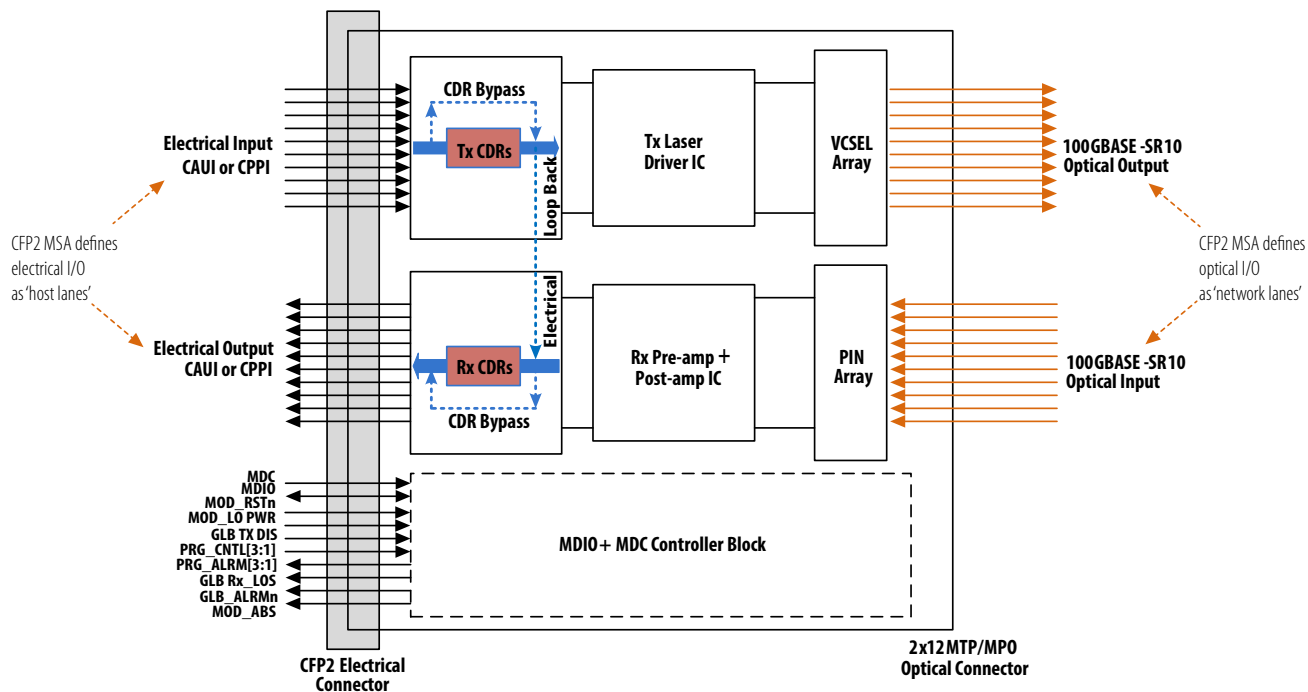

Figure 1. CFP2 Block Diagram

Key Product Parameters

Parameter	Value	Units	Notes
Data rate per lane	10.3125	Gbps	Compliant to 802.3ba 100GbE CAUI Specifications. Compliant to 802.3ba 100GbE CPPI Specifications (CDRs bypassed).
Number of operational lanes	10		Bi-directional
Link Length ^[1]	100 150	m m	OM3 OM4
Operating Temperature Range	0-70	°C	Case Temperature
Power Supply Voltage	3.3	V	Requires only 3.3 V Power rails
Management Interface			MDIO
Electrical Interface	104	contacts	As specified in the CFP2 industry agreement ^[2]
Optical Interface	24	Fibers	24-fiber MTP® (MPO) fiber optic connector
Laser Wavelength	850	nm	

Notes:

- Connector loss of 1.5 dB (OM3) / 1dB (OM4) allocated
- www.cfp-msa.org

This preliminary data is provided to assist you in the evaluation of product(s) currently under development. Until Avago Technologies releases this product for general sales, Avago Technologies reserves the right to alter prices, specifications, features, capabilities, functions, release dates, and remove availability of the product(s) at anytime.

For product information and a complete list of distributors, please go to our web site: www.avagotech.com

Avago, Avago Technologies, and the A logo are trademarks of Avago Technologies in the United States and other countries.
Data subject to change. Copyright © 2005-2013 Avago Technologies. All rights reserved.
AV02-4018EN - February 27, 2013

AVAGO
TECHNOLOGIES